

DRY BATTERY

DRY | CONVENTIONAL

REF **B49-6**



6v

VOLTAGE - v

10.5Ah

VOLTAGE - Ah (20Hr)

10Ah

CAPACITY - Ah (10Hr)

TECHNOLOGY

- Lead acid dry charged construction (absorbed acid)
- No acid in cells, must be filled with acid before use
- 6 & 12V batteries

FEATURES

- Upright installation only
- Has to be checked periodically and refilled with water if necessary
- Internal gas emission through venting hole
- Handle with care to prevent acid spillage
- Regular life duration
- Does not need to be recharged while stocked

DIMENSIONS

Length (A) :	91±2mm
Width (B) :	83±2mm
Container height :	160±2mm
Total height (C) :	160±2mm

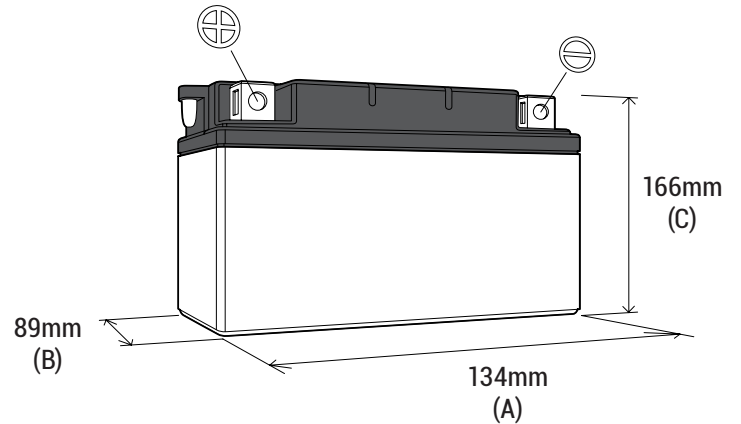

TERMINALS

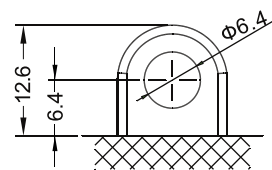

FRONT

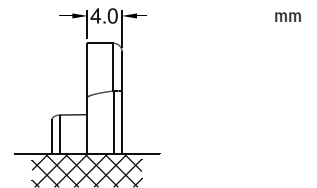

SIDE

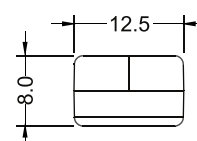

TOP

UPGRADE FOR

WEIGHT

Battery (with acid) : Approx 2.17kg

MOUNTING ANGLE

