

DRY BATTERY

DRY | CONVENTIONAL

REF BB16B-A



12V VOLTAGE - V

210A CCA - A

16.8Ah CAPACITY - Ah (20Hr)

16Ah CAPACITY - Ah (10Hr)

TECHNOLOGY

- Lead acid dry charged construction (absorbed acid)
- No acid in cells, must be filled with acid before use
- 6 & 12V batteries

FEATURES

- Upright installation only
- Has to be checked periodically and refilled with water if necessary
- Internal gas emission through venting hole
- Handle with care to prevent acid spillage
- Regular life duration
- Does not need to be recharged while stocked

UPGRADE FOR

WEIGHT

Battery (with acid) : Approx 5.13kg

MOUNTING ANGLE

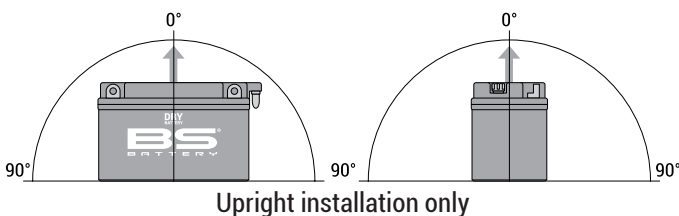

DIMENSIONS

| | |
|--------------------|---------|
| Length (A) : | 160±2mm |
| Width (B) : | 90±2mm |
| Container height : | 161±2mm |
| Total height (C) : | 161±2mm |

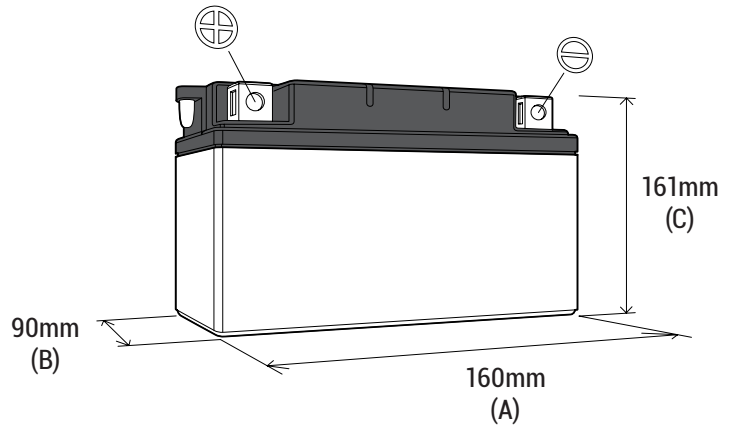

TERMINALS

