

**MF**  
BATTERY

**MF | MAINTENANCE FREE**

REF **BTX20HL-BS-PW**



**12V** VOLTAGE - V

**310A** CCA - A

**18.9Ah** CAPACITY - Ah (20Hr)

**18Ah** CAPACITY - Ah (10Hr)

## TECHNOLOGY

- AGM construction (absorbed acid)
- VRLA battery (Valve Regulated Lead Acid)
- Supplied with a separate acid pack
- Homologated by OEM

## FEATURES

- Upright installation only
- Maintenance free (no water refilling)
- Sealed after filling, no gas emission through venting hole (under normal operation)
- High power
- Does not need to be recharged while stocked
- Suitable for cold weather
- Reduction of plate sulfation
- Higher life cycle (up to three times longer than conventional batteries)
- Longer voltage hold

## UPGRADE FOR

-

## WEIGHT

Battery (with acid): Approx 6.02kg

## MOUNTING ANGLE

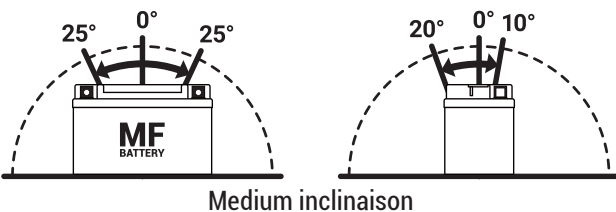

## DIMENSIONS

Length (A):	175mm ±2mm
Width (B):	87mm ±2mm
Container height:	175mm ±2mm
Total height (C):	175mm ±2mm

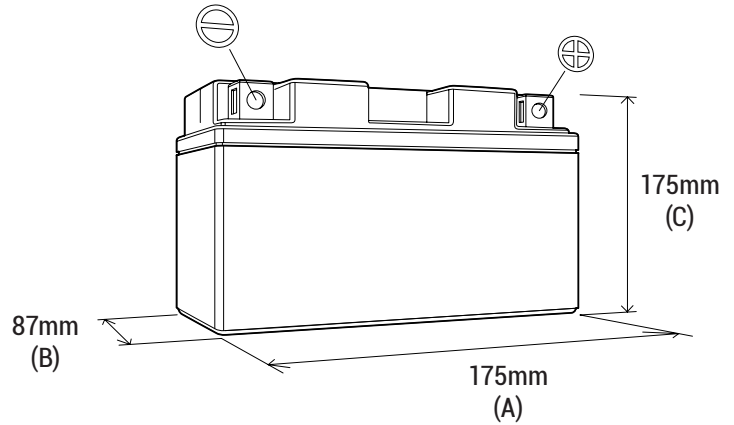

## TERMINALS (mm)

