

Ca/Ca BATTERY

Ca/Ca | CALCIUM TECHNOLOGY

REF **U1-12**



12v VOLTAGE - v

355A CCA - A (EN)

29Ah CAPACITY - Ah (10Hr)

TECHNOLOGY

- Designed according to AGM technology (Absorbed acid)
- Calcium technology
- Activated and pre-charged batteries
- Homologated by OEM

FEATURES

- Ready and easy to use
- Absolutely maintenance free
- No acid handling – very safe
- Increased power at extended service life
- Extreme vibration resistance
- Lightweight polypropylene container
- Heat-sealed container with flat top cover
- Venting systems
- Handle

UPGRADE FOR

WEIGHT

Battery (with acid) : Approx 8.42kg (18.57lbs)

MOUNTING ANGLE



Upright installation only

DIMENSIONS

Length (A) : 196±2mm (7.72in)
 Width (B) : 132±2mm (5.20in)
 Container height : 155±2mm (6.10in)
 Total height (C) : 180±2mm (7.09in)

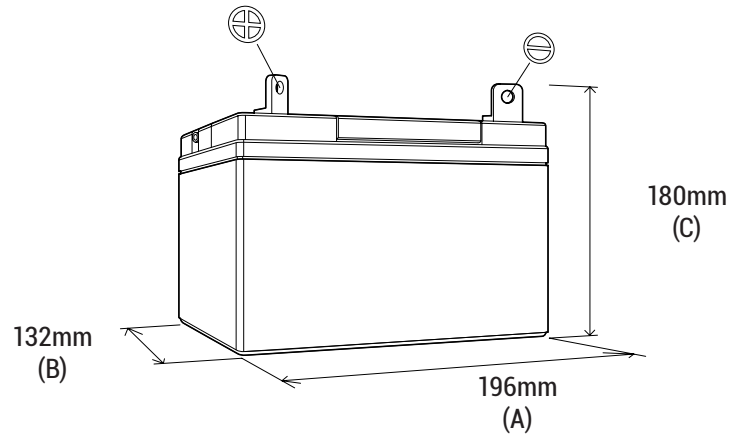

TERMINALS (mm)

