

DRY BATTERY

DRY | CONVENTIONAL

REF HBB16A-A/AB



12v VOLTAGE - v

210A CCA - A

16.8h CAPACITY - Ah (20Hr)

16Ah CAPACITY - Ah (10Hr)

TECHNOLOGY

- Lead acid dry charged construction (absorbed acid)
- No acid in cells, must be filled with acid before use
- 6 & 12V batteries

FEATURES

- Upright installation only
- Has to be checked periodically and refilled with water if necessary
- Internal gas emission through venting hole
- Handle with care to prevent acid spillage
- Regular life duration
- Does not need to be recharged while stocked

DIMENSIONS

Length (A):	151mm ±2mm
Width (B):	91mm ±2mm
Container height:	180mm ±2mm
Total height (C):	180mm ±2mm

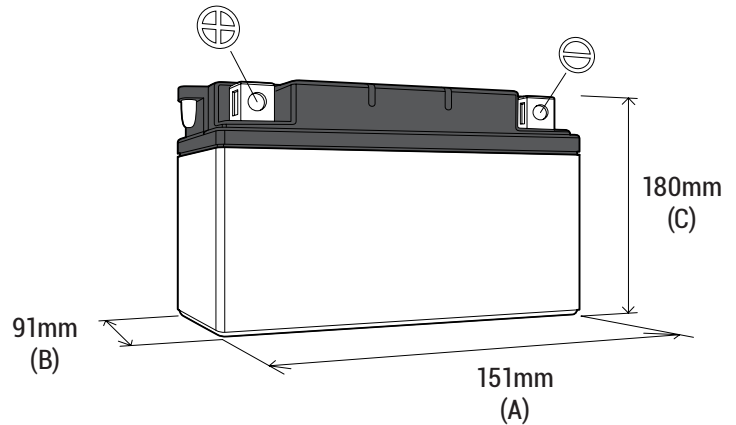

TERMINALS (mm)

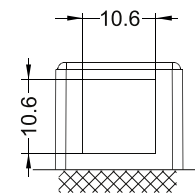

FRONT

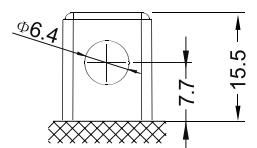

SIDE

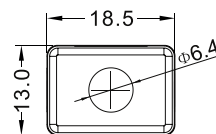

TOP

UPGRADE FOR

WEIGHT

Battery (with acid): Approx 5.06kg

MOUNTING ANGLE



Upright installation only