



BS Code: 300920

SLA

FACTORY ACTIVATED

SLA | READY TO START

REF **BTX20HL-PW**



12v VOLTAGE - v

310A CCA - A

18.9Ah CAPACITY - Ah (20Hr)

18Ah CAPACITY - Ah (10Hr)

TECHNOLOGY

- Designed according to AGM technology (Absorbed acid)
- VRLA battery type
- Activated and pre-charged batteries
- Homologated by OEM

FEATURES

- AGM construction (Absorbed Glass Material)
- VRLA battery (Valve Regulated Lead Acid)
- Factory activated
- Environmentally friendly, spillproof design
- Multi-positional fitment
- Absolutely Maintenance free
- Sealed, no gas emission through venting hole (under normal operation)
- Ready & Easy to use
- No acid handling - Very safe
- Increased power & Extended life
- Extreme vibration resistance

UPGRADE FOR

DRY BB18L-A ; BB16CL-B
MF BTX20L-BS ; BTX20HL-BS
SLA BB16CL-B

WEIGHT

Battery (with acid): Approx 6.04kg

MOUNTING ANGLE

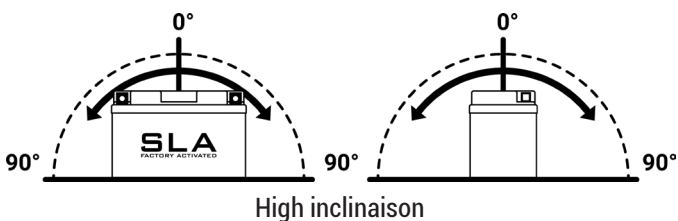

DIMENSIONS

Length (A):	175mm ±2mm
Width (B):	87mm ±2mm
Container height:	175mm ±2mm
Total height (C):	175mm ±2mm

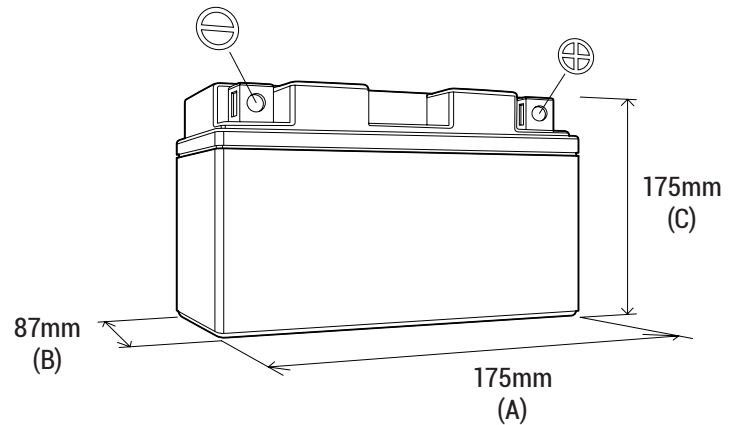

TERMINALS (mm)

