

## SLA<sup>MAX</sup>

FACTORY ACTIVATED

SLA MAX | PREMIUM QUALITY READY TO START

# REF BGZ20H



**12V** VOLTAGE - v

**360A** CCA

**21.1Ah** CAPACITY - Ah (20Hr)

**20Ah** CAPACITY - Ah (10Hr)

### TECHNOLOGY

- AGM construction (Absorbed Glass Material)
- VRLA battery (Valve Regulated Lead Acid)
- Activated and pre-charged batteries
- Homologated by OEM

### FEATURES

- Factory activated: Ready-to-start battery
- Totally sealed
- Safe & Environmentally friendly
- Superior capacity
- Increased power & Extended life
- Low discharge rate
- Absolutely maintenance free
- Sealed, no gas emission through venting hole (under normal operation)
- Extreme vibration resistance
- Spillproof design
- Multi-positional fitment
- No acid handling - Very safe

### UPGRADE FOR

MF BTX20-BS  
SLA BTX20

### WEIGHT

Battery (with acid): approx 6.96kg

### MOUNTING ANGLE

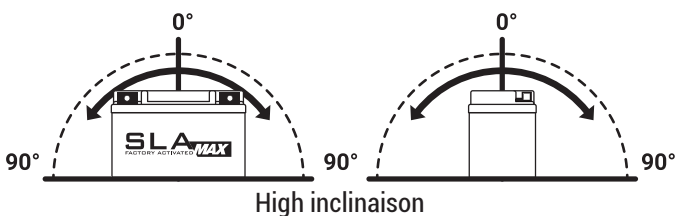

### DIMENSIONS

Length (A): 176mm ±2mm  
Width (B): 89mm ±2mm  
Container height: 154mm ±2mm  
Total height (C): 154mm ±2mm

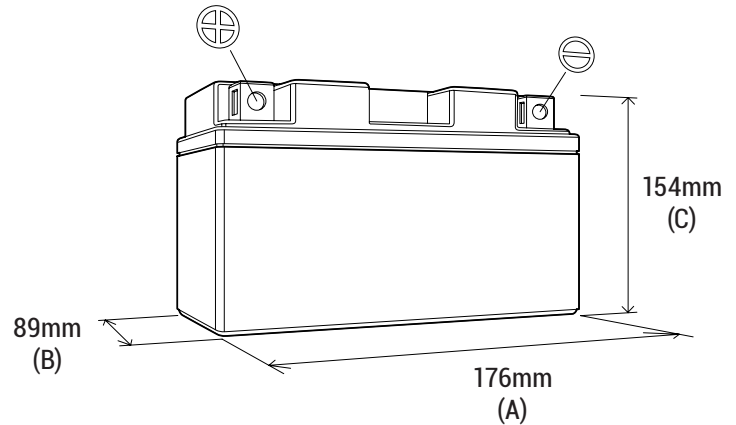

### TERMINALS (mm)

