



SLA^{MAX}

FACTORY ACTIVATED

SLA | READY TO START

REF U1-500



12V VOLTAGE - V

500A CCA - A

31.6Ah CAPACITY - Ah (20Hr)

30.0Ah CAPACITY - Ah (10Hr)

TECHNOLOGY

- AGM construction (Absorbed Glass Material)
- VRLA battery (Valve Regulated Lead Acid)
- Activated and pre-charged batteries
- Homologated by OEM

FEATURES

- Factory activated AGM (Absorbent Glass Mat) technology.
- Ready to use Just plug & play.
- No maintenance VRLA (Valve Regulated Lead Acid) design.
- Spill-proof design Factory sealed & electrolyte held in a glass fiber mat.
- No acid handling Very safe.
- Extreme vibration resistance Reinforced battery case.
- Maximum starting power & extended cycle life 40% higher than SLA CCA.
- Superior capacity 30% higher than SLA capacity.

UPGRADE FOR

WEIGHT

Battery (with acid): Approx 10.05kg (22.04lbs)

MOUNTING ANGLE

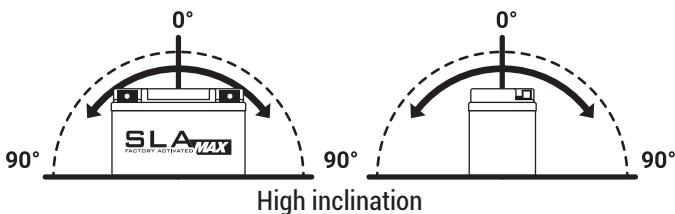

DIMENSIONS

Length (A):	195mm (7.67inch) ±2mm
Width (B):	125mm (4.92inch) ±2mm
Container height:	156mm (6.14inch) ±2mm
Total height (C):	176mm (6.92inch) ±2mm

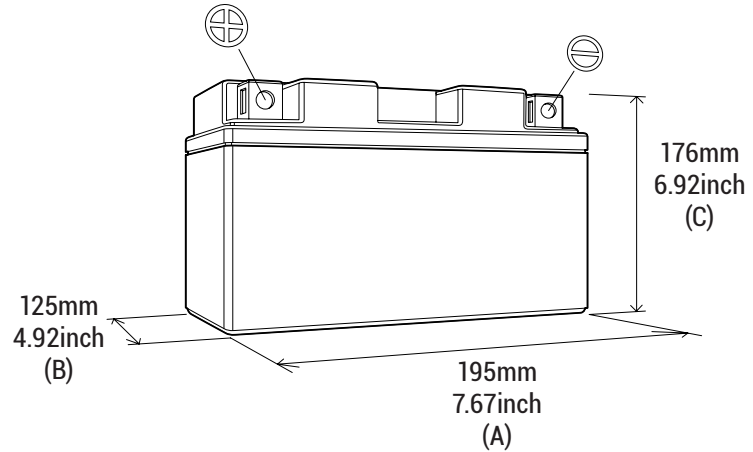

TERMINALS (mm)

