

6N2-2A

BS CODE: 300699

VOLTAGE **6V**

CCA -

CAPACITY 20HR **2.1Ah**

CAPACITY 10HR **2.0Ah**



DIMENSIONS

LENGTH	70 ±2mm	2.76 ±0.08inch
WIDTH	47 ±2mm	1.85 ±0.08inch
TOTAL HEIGHT	96 ±2mm	3.78 ±0.08inch
WEIGHT	0.43 kg ±5%	0.95 lbs ±5%

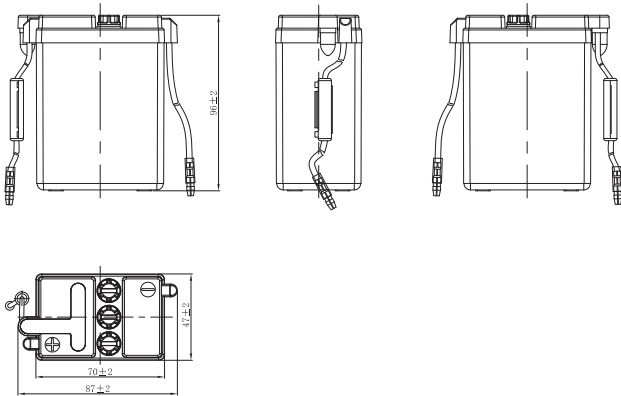





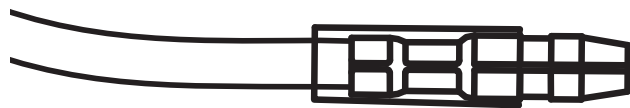

TERMINAL (mm)

POLARITY	
-----------------	--



DRY FEATURES

-  **TO BE ACTIVATED**
DRY-charged technology.
-  **ACID PACK INCLUDED**
For initial filling.
-  **PERIODIC MAINTENANCE**
Refilled with water if necessary.
-  **HANDLE WITH CARE TO PREVENT ACID SPILLAGE**
-  **LONG SHELF LIFE**
No need to be recharged while stocked (if not activated).
-  **INTERNAL GAS EMISSION THROUGH VENTING HOLE**
-  **WIDE VARIETY OF 6V & 12V MODELS**

MOUNTING ANGLE

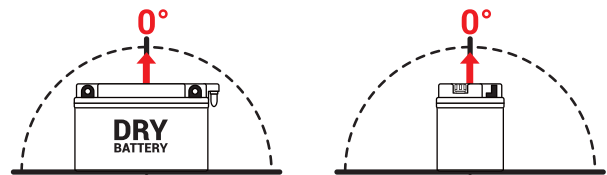

UPGRADE FOR

SLA MAX	SLA	MF	DRY
-	-	-	-