

BSLI-03

BS CODE: **360103**

VOLTAGE **12V**

ENERGY **36Wh**

CCA **210A**

CAPACITY 10HR **3.0Ah**



DIMENSIONS

LENGTH	134 ±2mm	5.28 ±0.08inch
WIDTH	65 ±2mm	2.56 ±0.08inch
TOTAL HEIGHT	92 ±2mm	3.62 ±0.08inch
WEIGHT	0.8 kg ±5%	1.76 lbs ±5%

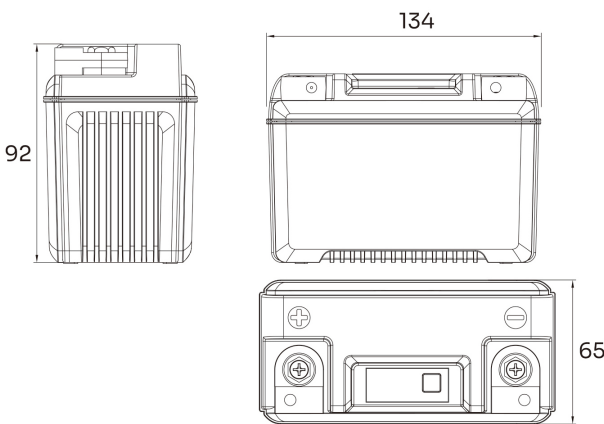

LITHIUM FEATURES

- READY TO USE**
Just plug & play.
- LIGHTER WEIGHT**
Up to 70% lighter than Lead Acid batteries.
- EXTENSIVE CYCLE LIFE**
Over 2 000 cycles.
- HEAT RESISTANCE**
Up to 230°C.
- ROBUST BRASS TERMINALS**
To enhance electrical performance.
- STATE OF CHARGE INDICATOR**
Monitor the state of charge with the indicator screen on the top.
- SPACERS**
For superior performance and limited vibrations, our Lithium batteries are much smaller than the Lead Acid ones. Different spacer types are delivered with each battery to fit the casing easily.

MOUNTING ANGLE

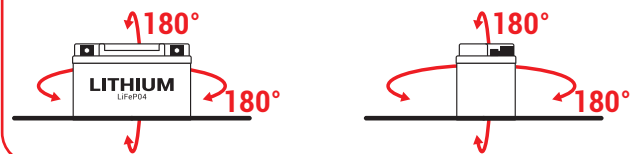

TERMINAL (mm)

POLARITY

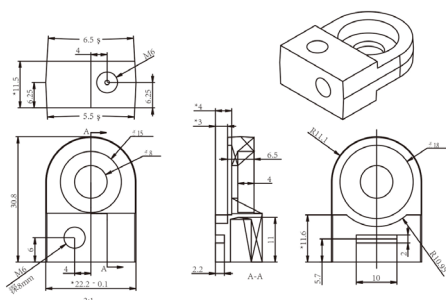

UPGRADE FOR

LITHIUM	SLA MAX	SLA	MF	DRY
-	-	BT7B-4 BT9B-4 BTX7A BTX9 BB7-A BB9-B	BT7B-BS BT9B-BS BTX7A-BS BTX9-BS BT9A-BS	BB7-A/12N7-4A BB9-B/12N9-4B-1