

BTX20H-BS

BS CODE: **300613**

VOLTAGE **12V**

CCA **310A**

CAPACITY 20HR **18.9Ah**

CAPACITY 10HR **18.0Ah**

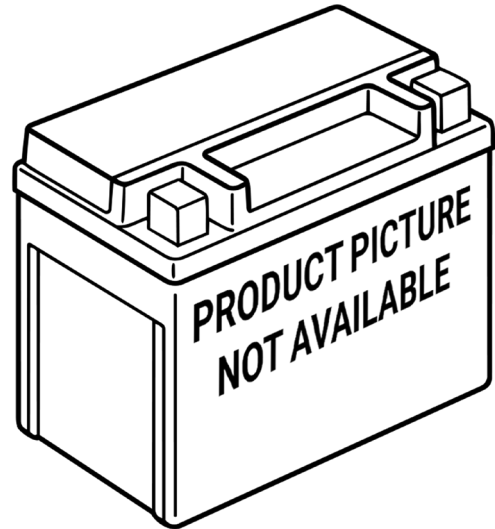

DIMENSIONS

LENGTH	175 ±2mm	6.89 ±0.08inch
WIDTH	87 ±2mm	3.43 ±0.08inch
TOTAL HEIGHT	155 ±2mm	6.1 ±0.08inch
WEIGHT	4.77 kg ±5%	10.52 lbs ±5%

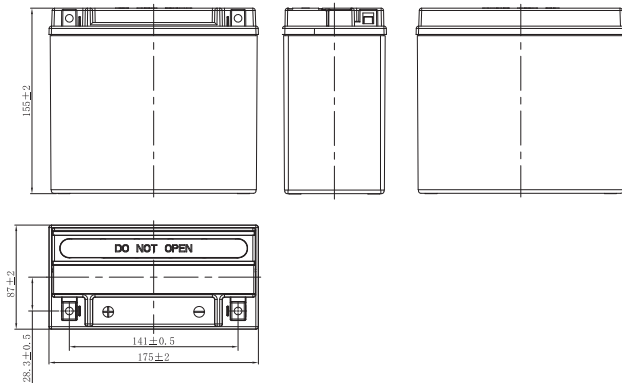

MF FEATURES

- TO BE ACTIVATED**
AGM (Absorbent Glass Mat) technology.
- ACID PACK INCLUDED**
For initial filling.
- NO MAINTENANCE***
VRLA (Valve Regulated Lead Acid) design.
- TIGHTLY SEALED AFTER FILLING**
Electrolyte is held in a glass fiber mat.
- SUPERIOR POWER & EXTENDED CYCLE LIFE**
- LONG SHELF LIFE**
No need to be recharged while stocked (if not activated).

*once activated

MOUNTING ANGLE

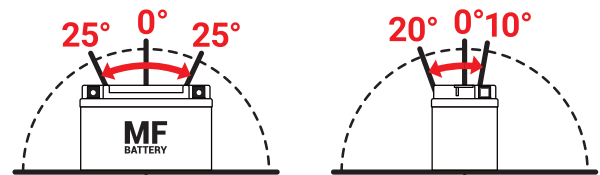

TERMINAL (mm)

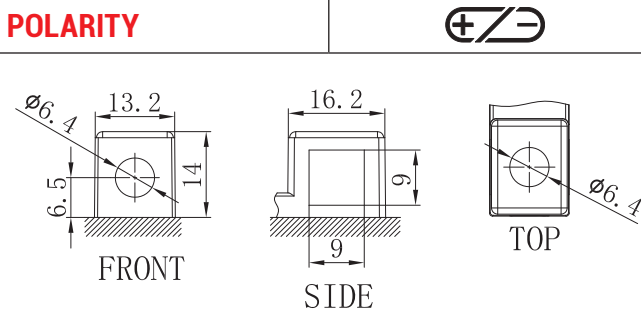

UPGRADE FOR

SLA MAX	SLA	MF	DRY
-	-	-	-